

187 Vonkprop Road
Samcor Park
Pretoria
0184
South Africa
P.O. Box 782, Silverton, 0127
Reg. No.: 1996/000393/23



Design, Manufacture and Supply of Earth Boring Machines and Equipment Ontwerp en Vervaardiging van Grond-boormasjiene en Toerusting

TECHNICAL SHEET: SR3000 BH (BLAST HOLE) DRILL RIG

The SR3000 Blast Hole Drill Rig is a robust and simple yet reliable and capable machine. This rig has no electronic systems that control any functions, thus eliminating untimely and unforeseen standing time due to dust ingress, thereby increasing machine availability, reliability and of course production.

The derrick is fabricated from hollow drawn steel tubes and hot-rolled sections. Sheave wheels are attached to the top and bottom of the derrick and steel wire rope is passed over them and fixed to a carriage that carries the rotary head. The carriage runs on heavy-duty sliding blocks which almost eliminates wear. A hydraulic cylinder is mounted within the derrick and is used to activate the up and down movement of the rotary head.

The rotary head consists of a single high torque rotary motor coupled to an air swivel with extra heavy-duty bearings which take all forces produced during drilling operations. The bull shaft on the air swivel has a choice of 4.5-inch REMET or 102 ARD or a 3.5" API thread to which the drill string is attached. A Hydraulic two-speed system comes standard on all machines.

Four hydraulic outriggers are fitted to the outer corners of the rig for easy and accurate levelling of the rig.

Twin hydraulic cylinders are used to raise and lower the derrick. All hydraulic controls are fitted into an ergonomic control panel within easy reach of the operator making the operation of the machine very easy and simple. A fingertip down feed valve ensures even pressures during drilling operations.

The working table consists of removable half-moons combined with replaceable guide collars, which when removed, easily allows 305mm diameter tools to pass through.

The drill rig's power pack consists of a six-cylinder Kirloskar engine close coupled to our tried and tested hydraulic system. All necessary air, fuel and oil filters are included.

Keeper keys, break-out spanners and a rod guide bush are supplied to suit the drill string.

A hydraulic rod breaker facilitates the breaking of stubborn drill rods.



Tel: +27 12 803 7925/6/7/8
Fax: +27 12 803 7085
E-mail: suprock@mweb.co.za
Sales E-mail: sales@superrockdrills.co.za
Website: www.superrockdrills.com
Export Customs Code: 00653225

Members: GGM JOOSTE (MANAGING), EVA KIRSTEIN



A 10-litre in-line oil lubricator for DTH hammer drilling is fitted as a standard.

The “SR3000 BH” is a very simple and easy machine to operate and maintain. Being locally designed and manufactured with over two hundred machines running in the mining, exploration, water well and piling industries proves that the “SR3000” range is a very popular and robust choice amongst drilling contractors.



Tel: +27 12 803 7925/6/7/8
Fax: +27 12 803 7085
E-mail: suprock@mweb.co.za
Sales E-mail: sales@superrockdrills.co.za
Website: www.superrockdrills.com
Export Customs Code: 00653225

Members: GGM JOOSTE (MANAGING), EVA KIRSTEIN



MAST	ROTARY HEAD
<p>Fabricated from hollow drawn steel tube and hot-rolled sections. Sheave wheels are attached to the top and bottom of the derrick and steel wire rope is passed over them and fixed to a carriage which carries the rotary head.</p> <p>Mast Raising Cylinders - 2</p> <p>Mast Locking - Hydraulic actuated pin</p> <p>Rod Loader Options - Hydraulically operated 7-rod carousel - Manually swung 8-rod carousel - Manually swung 6-rod carousel</p>	<p>Options</p> <ul style="list-style-type: none"> - Radial piston motor coupled to SRD air box @ 5250nm & 100 RPM - SRD Gearbox from 5250nm to 9000nm & 100 RPM
OPERATORS CAB	FEED SYSTEM
<p>Options</p> <ul style="list-style-type: none"> - Sound dampened to 84dB or less - Air-conditioned - Heated - Open 	<p>Type - Cylinder and 20mm steel wire rope via sheave wheels</p> <p>Pull Back - 12 Ton factoring in wire rope safety factor</p> <p>Down Force - 10 Ton</p> <p>Feed Speed Up Rate - 0.78m/s or 1.285s/m</p> <p>Feed Speed Down Rate - 1.3m/s or 0.76s/m</p> <p>Stroke - 7500mm / 7.5m</p>
DRILLING PARAMETERS	DECK ENGINE
<p>Hole Diameter - 3" - 12"</p> <p>Maximum Depth @ 6.5" - 300m (factoring in wire rope safety factor)</p> <p>Hydraulic Carousel Capacity - 42m</p> <p>Single Pass - 6m</p>	<p>Make - Kirloskar</p> <p>Engine Type - 6R1080T</p> <p>Rating kW/HP - 94/127</p> <p>RPM - 1800</p>
COMPRESSOR CAPACITY	UNDERCARRIAGE
<p>Flow Rate - 1200 CFM</p> <p>Pressure - 23 Bar</p>	<p>Capacity - 45 Ton</p> <p>Track Shoe Width - 500mm</p> <p>Width Over Track - 2640mm</p>
HYDRAULIC SYSTEM	DUST SUPPRESSION
<p>Reservoir Capacity - 1000 Litre</p> <p>Oil Type - Hydraulic 68</p> <p>Tramming Pump - Tandem 125cc Piston @ 400 Bar</p> <p>Rig Pumps - 4 Stages, Gear Pumps @ 200 Bar</p>	<p>Type - FMC A04 Water Injected</p> <p>Water Displacement - 34 Litre/Min</p> <p>Water Tank Capacity - 1000 Litre</p>
HAMMER LUBRICATION	GENERAL SPECIFICATIONS
<p>Type - Venturi system</p>	<p>Lighting - LED Lights</p> <p>No of Emergency Stops - 4</p> <p>Protection guards on all hot surfaces</p> <p>Strobe light on cab roof</p> <p>Lock-out protection</p>

Tel: +27 12 803 7925/6/7/8
 Fax: +27 12 803 7085
 E-mail: suprock@mweb.co.za
 Sales E-mail: sales@superrockdrills.co.za
 Website: www.superrockdrills.com
 Export Customs Code: 00653225

Members: GGM JOOSTE (MANAGING), EVA KIRSTEIN



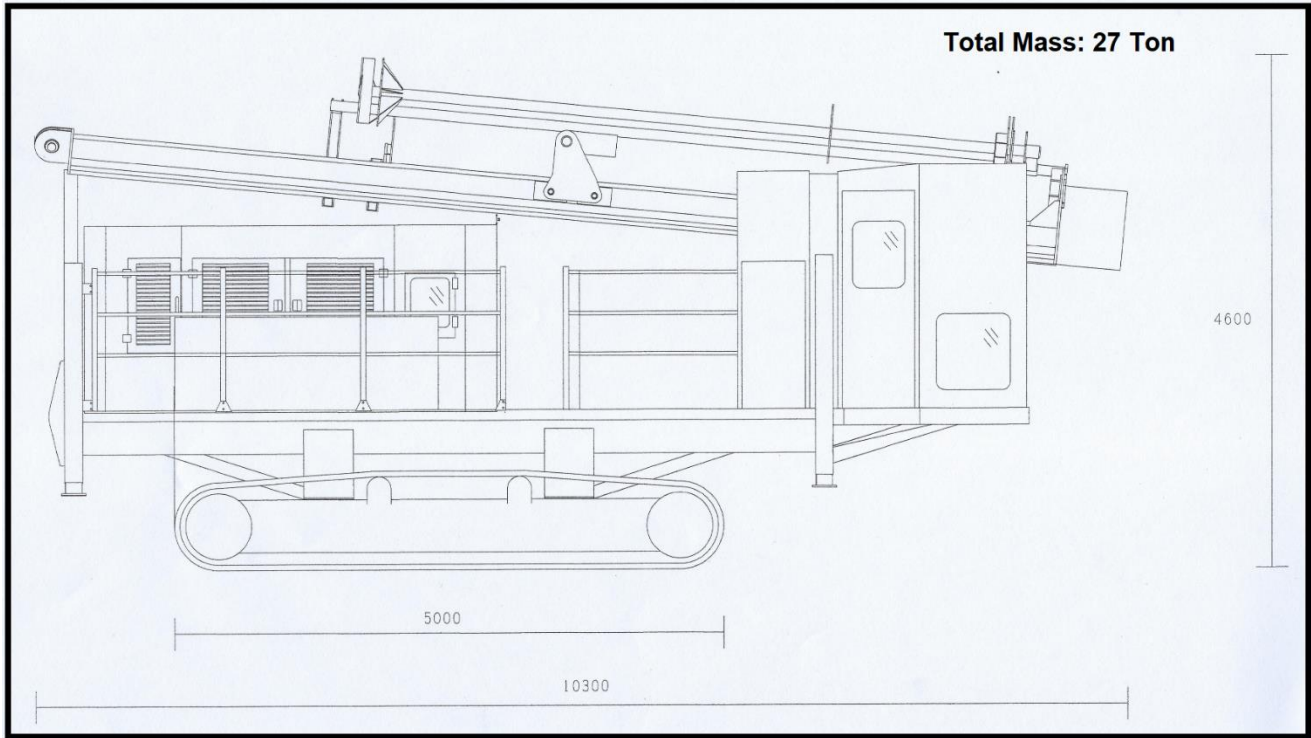

Total Mass: 27 Ton

4600

5000

10300

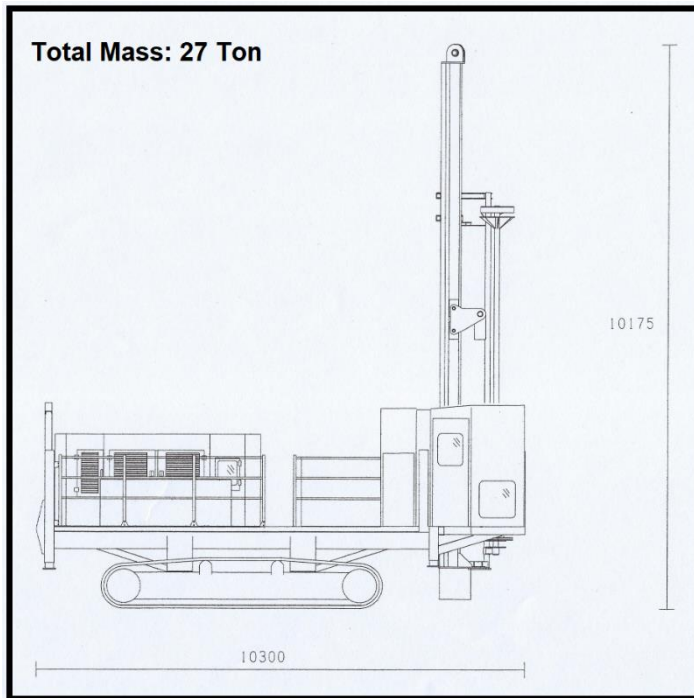

Total Mass: 27 Ton

10175

10300

LEFT HAND SIDE VIEW –
MAST DOWN

LEFT HAND SIDE VIEW –
MAST UP

Tel: +27 12 803 7925/6/7/8
 Fax: +27 12 803 7085
 E-mail: suprock@mweb.co.za
 Sales E-mail: sales@superrockdrills.co.za
 Website: www.superrockdrills.com
 Export Customs Code: 00653225

Members: GGM JOOSTE (MANAGING), EVA KIRSTEIN



Total Mass: 27 Ton

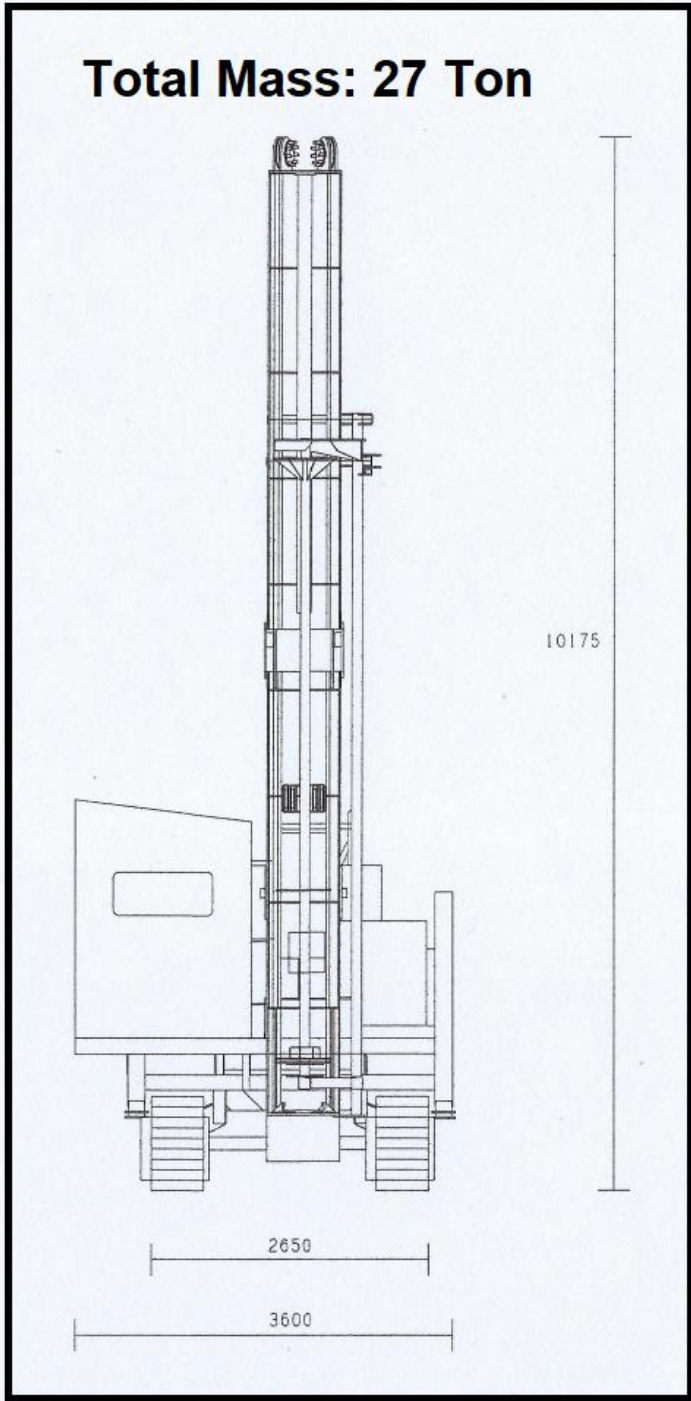

Total Mass: 27 Ton

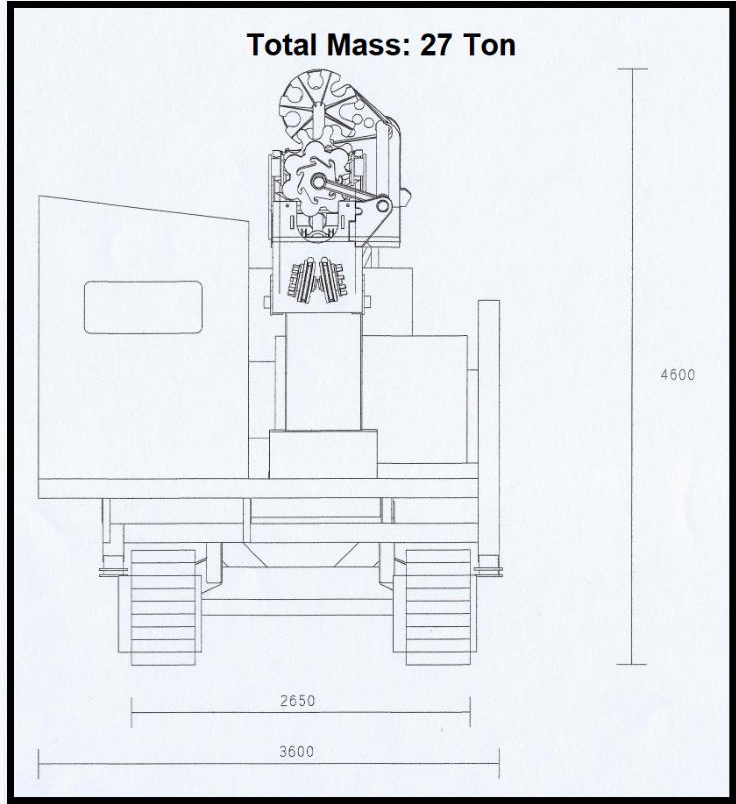

REAR VIEW –
MAST DOWN

REAR VIEW –
MAST UP

Tel: +27 12 803 7925/6/7/8
Fax: +27 12 803 7085
E-mail: suprock@mweb.co.za
Sales E-mail: sales@superrockdrills.co.za
Website: www.superrockdrills.com
Export Customs Code: 00653225

Members: GGM JOOSTE (MANAGING), EVA KIRSTEIN

